

HUSKY[®]

HYLECTRIC 4.0[™]

Evolution of a High-Performance
Packaging Molding Platform



THE GOLD STANDARD IN PACKAGING MOLDING

Husky has industry-leading packaging molding experience and technology expertise. Building upon this proven track record, our Hylectric 4.0™ injection molding machines offer superior levels of productivity, versatility and ease of use.

The latest generation Hylectric 4.0™ includes all of the standard features and configurations of previous generations, with capabilities to enhance connectivity, control, energy management and streamline operator experience.

Hylectric 4.0™ is designed to support aggressive cycle times for a wide range of applications like thinwall packaging, pails, closures and medical devices. Wide tie-bar spacing combined with Reflex™ platens offer better tonnage utilization for high part quality consistency and longer mold life as a stand-alone machine or as a part of an integrated system.

Flexible interface options, Industry 4.0 connectivity, intelligent networking and intuitive controls make Hylectric 4.0™ the heart of a truly integrated workcell.

THINWALL PACKAGING AND PAILS



SPECIALTY AND FLIP-TOP CLOSURES



MEDICAL AND PERSONAL CARE PARTS



COMPREHENSIVE MATRIX FOR GREAT PERFORMANCE FLEXIBILITY

To meet growing demands for performance flexibility, Husky offers a comprehensive matrix of Hylectric 4.0™ machines. A wide range of sizes and performance options enable optimal production solution configurations for each part's unique molding needs.

Hylectric 4.0™ machines are available from 120 to 1200 metric tons with a broad selection of injection units. Longer versions of the clamping unit are available for large shut-height tools.

	RS28	RS35	RS40	RS45	RS55	RS65	RS80	RS95	RS115	RS135
H(L)120	■	■	■	■	■					
H(L)160		■	■	■	■					
H(L)225				■	■	■	■			
H(L)300				■	■	■	■	■		
H(L)400					■	■	■	■	■	
H(L)500						■	■	■	■	
H(L)600							■	■	■	■
H650							■	■	■	■
H800							■	■	■	■
H(L)1000								■	■	■
H(L)1200									■	■

HIGH MACHINE CAPABILITY

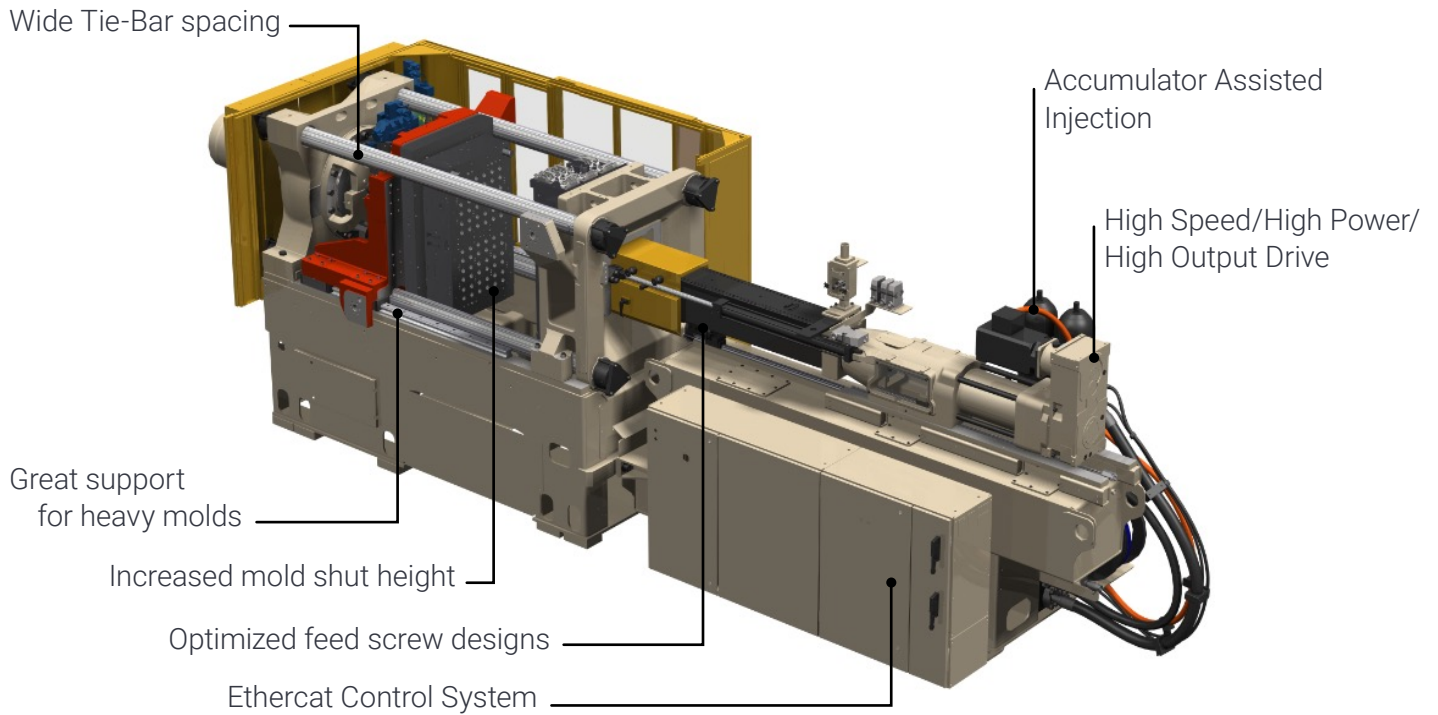

PART QUALITY CONSISTENCY

Hylectric 4.0™ machines are equipped with Husky's distinctive three-platen clamping unit. The Reflex™ platen is designed to enable uniform clamping force distribution across the entire molding surface, for part-to-part consistency and quality.

Superior tonnage distribution helps to reduce clamping force and mold wear. This, combined with wide tie-bar spacing, large platens and a stiff clamp base, make Hylectric 4.0™ ideally equipped to run heavy, high cavitation molds that would typically require larger conventional machines.

Hylectric 4.0™ machines can also run stack molds to deliver significant productivity improvements. A Unique Stack Mold Carrier (SMC) doubles system output without increasing footprint, making this an effective solution for projects with high output requirements.

- Mounted on linear bearings, the stack mold carrier can support heavy loads and high speeds
- Bearings typically move along rails attached to the clamp base ensuring a solid set-up that alleviates shifting
- A distinguishing feature of the carrier is a harmonic linkage mechanism connected to the machine platens that synchronizes the opening and closing of all parting lines keeping them perfectly aligned and parallel to each other

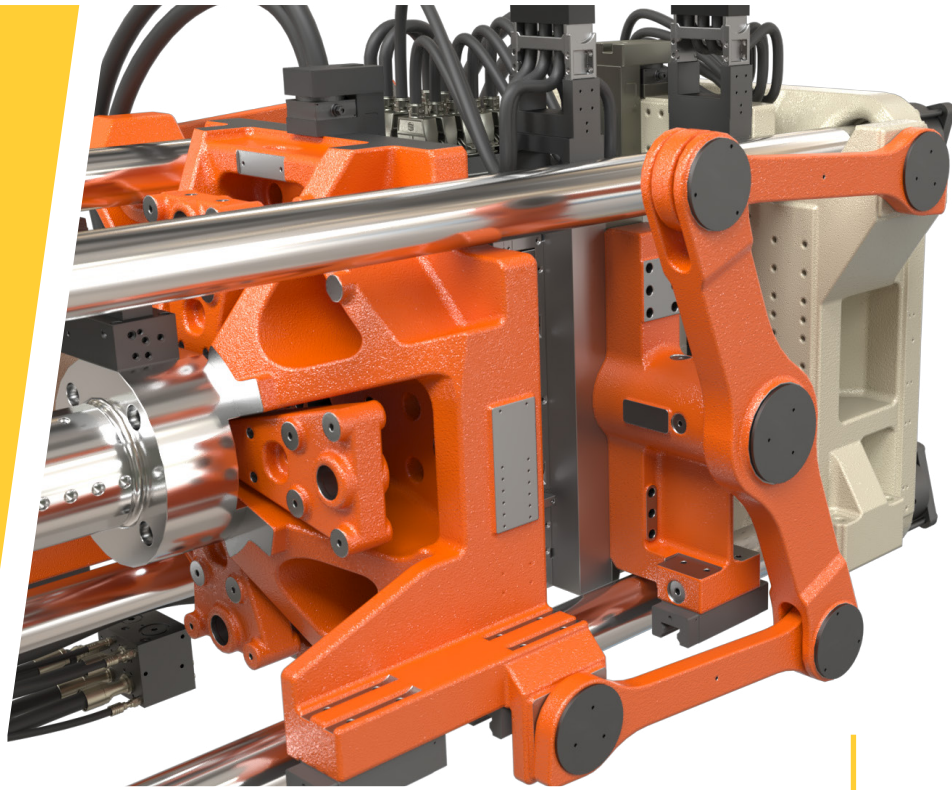

Stack molds (with two or more parting lines) can be used for increasing productivity on a wide range of applications like closures, thinwall containers, lids and medical applications.

Husky's distinctive three-platen clamping unit is gentle on the mold, reducing unscheduled downtime and extending tool life. The unique design of the Reflex™ platen allows it to conform to the mold to significantly reduce wear.

INJECTION UNIT TECHNOLOGIES

Hylectric 4.0™ Reciprocating Screw injection units provide best-in-class throughput capabilities at high speed and pressure injection rates. This, combined with high quality melt, maximizes part quality for demanding applications like thinwall in-mold-labelled packaging, medical devices and closures

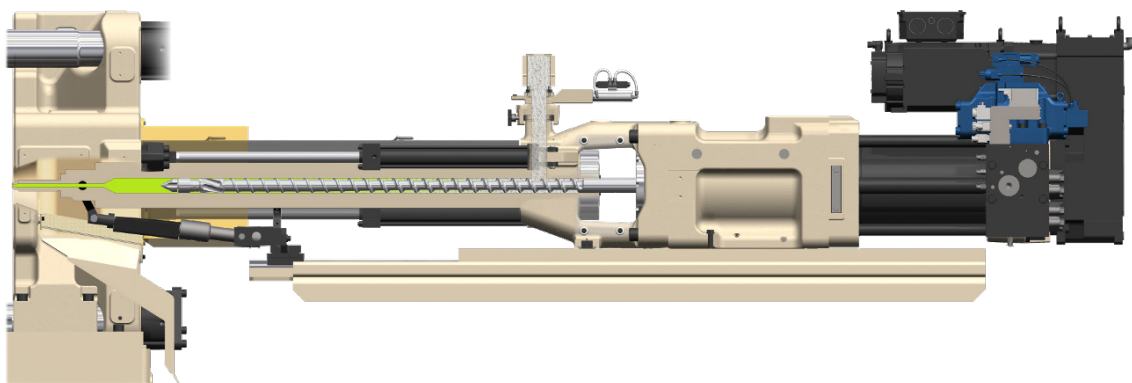

In case of extra high throughput application requirements, Hylectric 4.0™ machines can be equipped with two-stage injection units for superior performance and throughput capabilities. These injection units separate the plasticizing and injection functions, allowing the extruder to be sized for maximum throughput and the shooting pot sized for precise shot control.

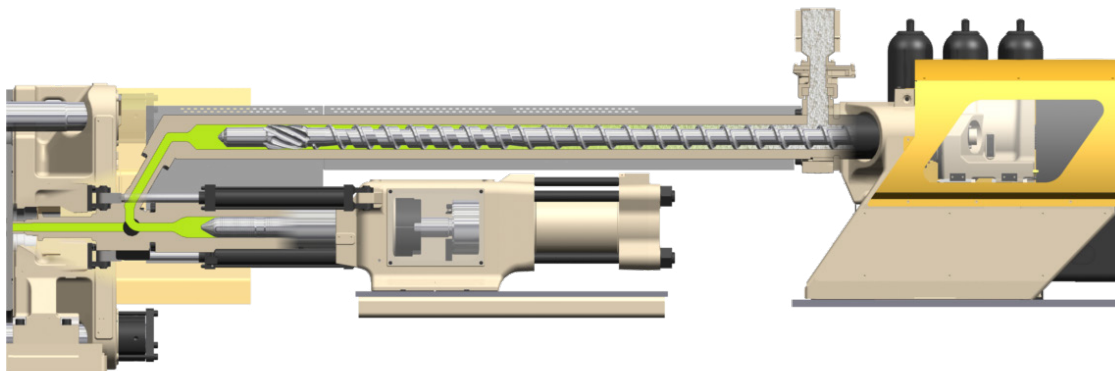

VARIABLE SYSTEM PRESSURE

To provide optimal energy usage, built-in intelligent adaptive software adjusts machine hydraulic system pressure based on specific application needs (cycle time, clamp tonnage, injection speed, injection pressure, etc.). Once enabled, this software studies current cycle times by monitoring the required pressure at each machine axis at different stages of the machine cycle. This learning enables the system to adjust system pressure accordingly to reduce energy consumption without sacrificing performance and part quality.



A large touchscreen enables system-level control, easy navigation and simplified operation.

CONNECTED SERVICES

Advanced control and software features simplify operation and optimize the manufacturing process. Husky's Polaris® control enables system-level control from a single 19-inch HMI, with intuitive screens that are easy to navigate. Quick access to critical process parameters and information enables faster start-ups and maximizes overall productivity. Advanced connectivity enables remote diagnostics and allowing for easy connection to process and productivity monitoring software.

IMPROVED TOOLING AND AUXILIARY EQUIPMENT INTERFACES

Hylectric 4.0™ configuration can be tailored to individual production requirements and can be equipped with:

- Modular air valves with pressure regulators
- Hydraulic and pneumatic core-pulls with additional programming freedom for complex molding sequences
- Standard or high-density mold cooling manifolds
- Wide selection of nozzle tips
- Extended split rails for stack molds
- Smart conveyor interface
- Configurable input and output signals
- Multiple interfaces for Husky Altanium™ temperature controllers

UNLOCKING PACKAGING POSSIBILITIES FOR TWO-COMPONENT MOLDING

Hylectric 4.0™ machines can be equipped with an additional second injection unit to support molding of two-component applications like PCR pails, specialty closures and medical parts. Controls for the second injection unit are fully integrated in the machine HMI for easy set up and operation.

For PCR pails specifically, Husky's co-injection technology combines the benefits of a robust, high performing and easy-to-maintain system with the capability to precisely dose the added layer for the ideal combination of product protection, package design and innovative decorative capabilities.

The second injection unit can be placed in different locations depending on the application and tooling requirements. Controls for second injection unit are fully integrated in machine HMI for easy set up and operation.

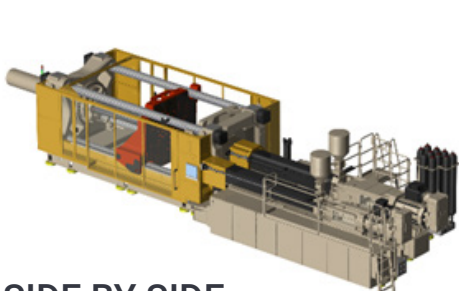

SIDE BY SIDE

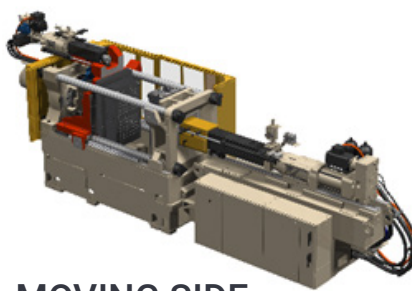

MOVING SIDE



STATIONARY SIDE

DELIVERING ON OUR COMMITMENT TO CUSTOMERS

Husky strives to provide unparalleled service and support. In addition to producing robust machines and high-performance systems, we also provide delivery and documentation, start-up service at the customer site, troubleshooting, advisory services and extensive training.

Our mold and machine manufacturing facilities help customers bring products to market faster by providing manufacturing flexibility and the capacity to handle projects of any size in a quick and timely manner. Each location is equipped with state-of-the-art technology and equipment enabling machines and tooling to be produced independently in all locations, with the same high level of quality.

This is all supported by our Husky Advantage+Elite™ proactive, predictive and transparent monitoring solution. Introduced early in 2020, Husky Advantage+Elite™ monitors systems within customers' production facilities in real-time while proactively engaging to secure and maintain the lowest total cost to produce and strives to ensure customer equipment is continuously running at peak capacity.



HUSKY®
Advantage+Elite™
WE CALL YOU



HUSKY COMPLETE™

The industry's only **complete, connected, end-to-end** production solution.

Husky COMPLETE™ enables packaging producers to transform variability into stability throughout every stage of production – to produce the highest quality, most sustainable packaging with world-class productivity and at the lowest cost. Husky COMPLETE is supported by Husky's latest generation platform of proven Hylectric 4.0™ systems.

HUSKY COMPLETE™ SUPPORTS EVERY STAGE OF PRODUCTION

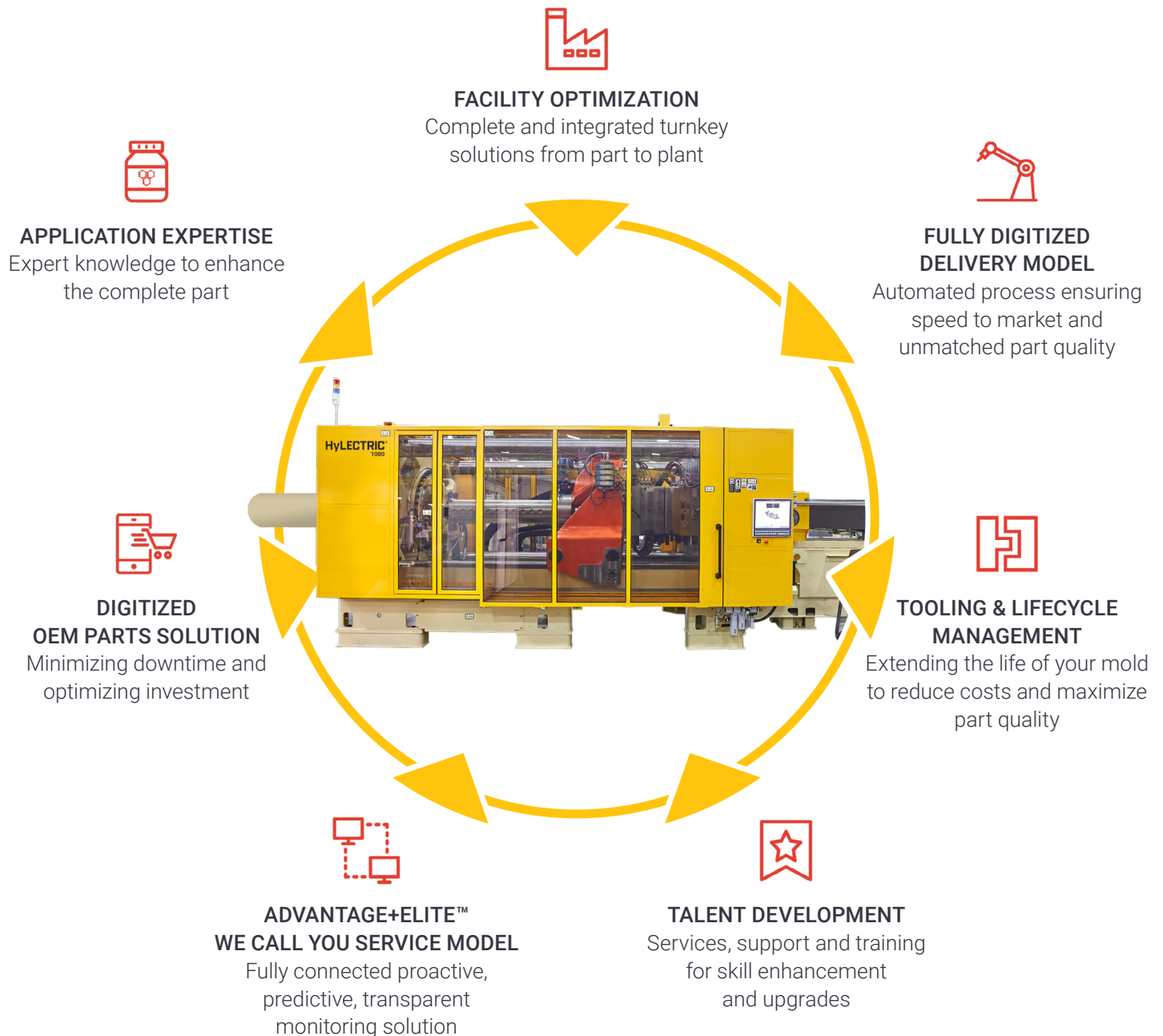

Husky offers a diverse range of solutions to meet your thinwall, industrial packaging, specialty closures and medical application molding needs. Contact us to learn more about our Hylectric 4.0™ machine solution.



HUSKY®

Husky Technologies™
husky.co

Head Office Canada • Tel (905) 951 5000 • Fax (905) 951 5384
Asia Pacific China • Tel (86) 21 2033 1000 • Fax (86) 21 5048 4900
Europe Luxembourg • Tel (352) 52 11 51 • Fax (352) 52 60 10

Husky Technologies™ is a registered trade-mark of Husky Technologies™ in the United States and other countries, and may be used by certain of its affiliated companies under License. All HUSKY products or service names or logos referenced in these materials are trade-marks of Husky Technologies™ and may be used by certain of its affiliated companies under License.

© 2022 Husky Technologies™. All rights are reserved.

Disclaimer: Information is made available in this flyer "as is" and no warranties are given or liabilities of any kind are assumed with respect to the quality of such Information, including, but not limited to, its fitness for a purpose, non-infringement of third party rights, accuracy, completeness or its correctness. Except as set forth in Husky's written warranty, Husky makes no additional warranties, whether express, implied or statutory. Certain conditions may apply. For more details please request a copy of Husky's written warranty and Standard Terms and Conditions.*